



Lamp/Ballast Retrofit Kits ST SERIES

Project: _____
 Part Number: _____
 Quantity: _____



APPLICATIONS

- RETROFITS
 - Shoebox
 - Flood Lights
 - Specialty Fixtures
 - Indoor Linear Fixtures

FEATURES

- 100,000 Hour Lifespan (IESNA)
- 5 Year or 30,000 Hour Warranty
- Square Profiled or Die-Casted Aluminum Ballast Housing
- Includes Mounting Hardware
- Ambient Temp Range: -30 to 120 deg F



LAMP/GENERATOR

- 120-277V Universal Electronic Ballast
- Available 0-10V Dimmability, 2-way Communication
- Power Factor > 0.95, Operation Frequency 50-60Hz
- Instant-On, Flicker Free, Minimum Light Loss
- 40W—400W Square Tubular Lamp Design
- Color Temps Available: 3000K—5000K
- CRI > 85—Excellent Color Rendition



Product #	Wattage	Replaces	Lm/W	Lumens	Voltage	Current (A)	Input Pwr (W)
MHT-ST-40E	40	MH - 70W HPS - 100W	72.5	2,900	120/277	0.16 - 0.35	42
MHT-ST-55E	55	MH - 100W HPS - 100W	72.5	3,988	120/277	0.21 - 0.49	58
MHT-ST-70E	70	MH - 120W HPS - 150W	72.5	5,075	120/277	0.27 - 0.62	74
MHT-ST-80E	80	MH - 150W HPS - 150W	77.5	6,200	120/277	0.32 - 0.70	84
MHT-ST-100E	100	MH - 200W HPS - 200W	77.5	7,750	120/277	0.40 - 0.93	105
MHT-ST-120E	120	MH - 200W HPS - 200W	77.5	9,300	120/277	0.45 - 1.05	126
MHT-ST-150E	150	MH - 250W HPS - 300W	82.5	12,375	120/277	0.59 - 1.36	158
MHT-ST-200E	200	MH - 360W HPS - 400W	82.5	16,500	120/277	0.77 - 1.79	210
MHT-ST-250E	250	MH - 400W HPS - 500W	87.5	21,875	120/277	1.05 - 2.19	263
MHT-ST-300E	300	MH - 500W HPS - 500W	87.5	26,250	120/277	1.20 - 2.63	315
MHT-ST-400E	400	MH - 1000W HPS - 1000W	87.5	35,000	120/277	1.44 - 3.33	420

Available Options:

- Dimmable Ballast



Lamp/Ballast Retrofit Kits

ST SERIES

Project: _____
 Part Number: _____
 Quantity: _____

ORDERING CODES

MHT-LST - **E** - -

Wattage:
 40, 55, 70, 80, 100,
 120, 150, 200, 250,
 300, 400

Color Temp:
 3K = 3000K
 4K = 4000K
 5K = 5000K

Voltage:
 U = Universal
 3 = 347V

Dimmable Ballast:
 DB

DIMENSIONS

LAMP DIMENSIONS

inches (mm)	Dia	W	L
MHT-ST-40E	1.7 (42)	4.5 (114)	8.1 (204)
MHT-ST-55E	1.7 (42)	4.5 (114)	8.1 (204)
MHT-ST-70E	2.1 (54)	5.5 (140)	9.9 (250)
MHT-ST-80E	2.1 (54)	5.5 (140)	9.9 (250)
MHT-ST-100E	2.1 (54)	5.5 (140)	11.8 (300)
MHT-ST-120E	2.1 (54)	5.5 (140)	13.4 (340)
MHT-ST-150E	2.1 (54)	5.5 (140)	15.4 (390)
MHT-ST-200E	2.3 (58)	7.4 (186)	17.3 (438)
MHT-ST-250E	2.3 (58)	7.4 (186)	23.2 (588)
MHT-ST-300E	2.3 (58)	7.4 (186)	27.1 (688)
MHT-ST-400E	2.3 (58)	7.4 (186)	35.0 (888)

BALLAST DIMENSIONS

inches (mm)	L	W	H
MHT-ST-40E	7.0 (177)	4.1 (105)	1.9 (48)
MHT-ST-55E	7.0 (177)	4.1 (105)	1.9 (48)
MHT-ST-70E	7.0 (177)	4.1 (105)	1.9 (48)
MHT-ST-80E	7.0 (177)	4.1 (105)	1.9 (48)
MHT-ST-100E	7.0 (177)	4.1 (105)	1.9 (48)
MHT-ST-120E	8.4 (213)	4.8 (120)	2.1 (53)
MHT-ST-150E	8.4 (213)	4.8 (120)	2.1 (53)
MHT-ST-200E	8.4 (213)	4.8 (120)	2.1 (53)
MHT-ST-250E	12.6 (319)	7.5 (190)	3.0 (76)
MHT-ST-300E	12.6 (319)	7.5 (190)	3.0 (76)
MHT-ST-400E	12.6 (319)	7.5 (190)	3.0 (76)

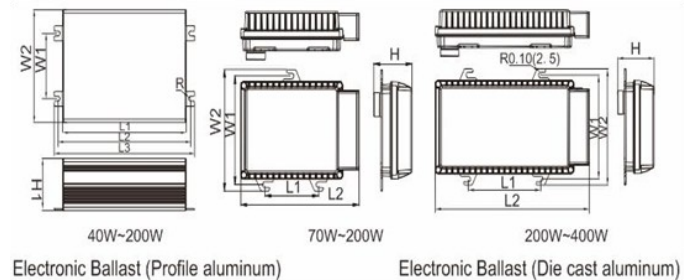
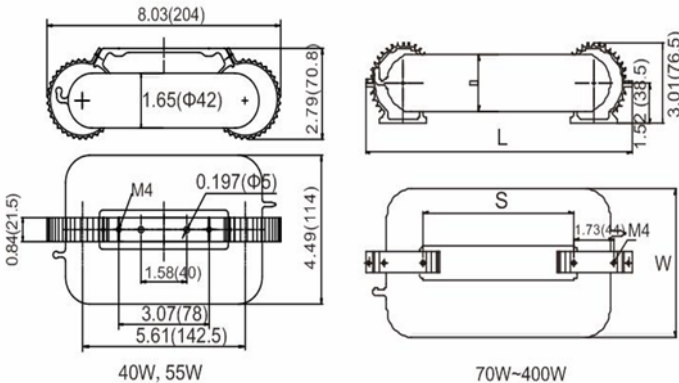

- ▶ **MHT Products are UL Listed/Labeled and Assembled in ISO9000/1 Certified US Facility**
- ▶ **Every product is quality tested and inspected prior to shipment**
- ▶ **MHT Lighting offers a 5-year, 30,000 hour Warranty (please see Warranty Terms and Conditions)**

MHT Plant Operations
 1961 Richmond Terrace
 Staten Island, NY 10302
 Ph: (718) 524-4370, Fx: (718) 524-4390

West Coast Operations
 2285 Michael Faraday Dr, Ste 15
 San Diego, CA 92154
 Ph: (619) 661-0600, Fx: (619) 661-0607