



# Wall Pack Fixtures WP SERIES

Project: \_\_\_\_\_  
 Part Number: \_\_\_\_\_  
 Quantity: \_\_\_\_\_



## APPLICATIONS

- Building Exterior
- Garages
- Parking Lots
- Safety Lighting
- Perimeter Lighting

## FEATURES

- 100,000 Hour Lifespan (IESNA)
- 10 Year or 60,000 Hour Warranty
- High Pressure Die-casted, Powder Coated Aluminum Housing
- Prismatic Tempered Glass Lens
- Surface Mounting with Bracket
- Ambient Temp Range: -30 to 130 deg F



## LAMP/GENERATOR

- 120-277V Universal Electronic Ballast
- Available 0-10V Dimmability, 2-way Communication
- Power Factor > 0.95, Operation Frequency 50-60Hz
- Instant-On, Flicker Free, Minimum Light Loss
- 40W—100W Square Tubular Lamp Design
- Color Temps Available: 3000K—5000K
- CRI > 85—Excellent Color Rendition

Product #	Wattage	Replaces	Lm/W	Lumens	IP Rating	Size	Lens
MHT-WP-40E	40	MH - 70W HPS - 100W	72.5	2,900	54	18"x9"	Prismatic Glass
MHT-WP-55E	55	MH - 100W HPS - 100W	72.5	3,988	54	18"x9"	Prismatic Glass
MHT-WP-70E	70	MH - 120W HPS - 150W	72.5	5,075	54	18"x9"	Prismatic Glass
MHT-WP-80E	80	MH - 150W HPS - 150W	77.5	6,200	54	18"x9"	Prismatic Glass
MHT-WP-100E	100	MH - 200W HPS - 200W	77.5	7,750	54	18"x9"	Prismatic Glass

### Available Options:

- Dimmable Ballast
- Occupancy Sensor
- Photocell
- Custom Colors Available



# Wall Pack Fixtures WP SERIES

Project: \_\_\_\_\_  
Part Number: \_\_\_\_\_  
Quantity: \_\_\_\_\_

## ORDERING CODES

MHT-WP - [ ] E - [ ] [ ] - [ ] - [ ]

**Wattage:**  
40, 55, 70,  
80, 100

**Color Temp:**  
3K = 3000K  
4K = 4000K  
5K = 5000K

**Voltage:**  
U = Universal  
3 = 347V

**Dimmable  
Ballast:**  
DB

**Options:** (please specify voltage)  
OSD = Occ Sensor w/ Step Dim  
OSI = Occ Sensor w/ Instant On  
PC = Photocell, CC = Custom Color

## DIMENSIONS

MHT-WP-40/55/70/80/100E

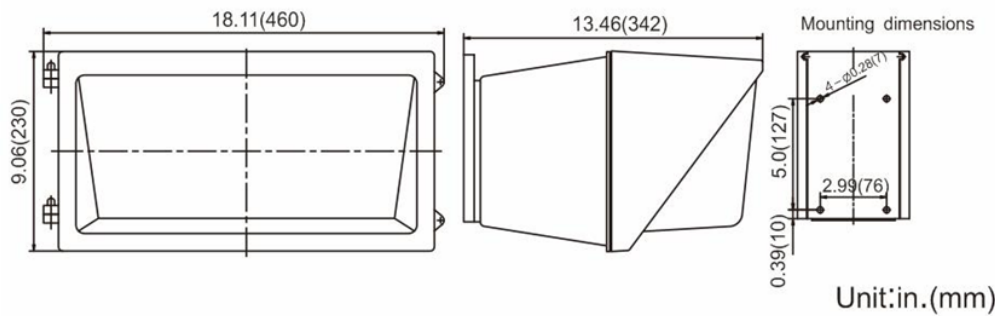

## SAMPLE PHOTOMETRICS

MHT-WP-80E

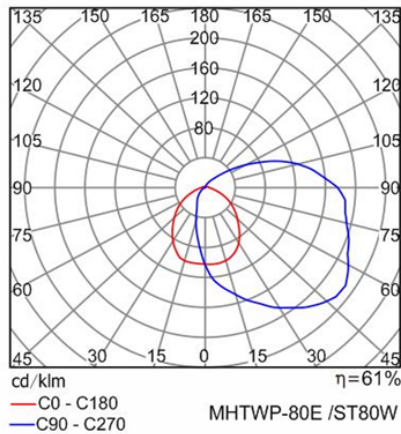

MHT-WP-100E

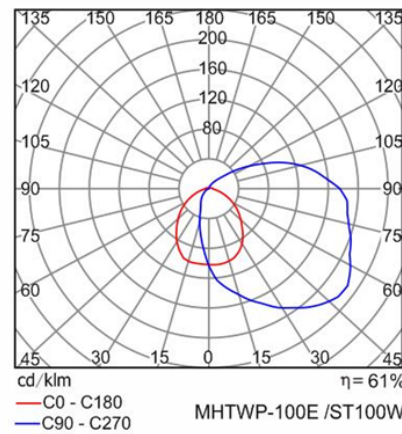

- MHT Products are UL Listed/Labeled and Assembled in ISO9000/1 Certified US Facility
- Every product is quality tested and inspected prior to shipment
- MHT Lighting offers a 10-year, 60,000 hour Warranty (please see Warranty Terms and Conditions)
- Made in the USA of US and Imported Parts, Meets Buy American requirements within the ARRA

MHT Plant Operations  
1961 Richmond Terrace  
Staten Island, NY 10302  
Ph: (718) 524-4370, Fx: (718) 524-4390

West Coast Operations  
2285 Michael Faraday Dr, Ste 15  
San Diego, CA 92154  
Ph: (619) 661-0600, Fx: (619) 661-0607