



Tunnel Fixtures TL SERIES

Project: _____
 Part Number: _____
 Quantity: _____



APPLICATIONS

- Tunnels
- Overpasses
- Area/Safety Lighting
- Food Storage
- Agricultural

FEATURES

- 100,000 Hour Lifespan (IESNA)
- 10 Year or 60,000 Hour Warranty
- Square Profiled, Powder Coated Aluminum Housing
- Clear Tempered Glass Lens
- Gas-tight Silicon Seal for Wet Locations
- Surface Mounting with Bracket
- Ambient Temp Range: -30 to 130 deg F



LAMP/GENERATOR

- 120-277V Universal Electronic Ballast
- Available 0-10V Dimmability, 2-way Communication
- Power Factor > 0.95, Operation Frequency 50-60Hz
- Instant-On, Flicker Free, Minimum Light Loss
- 100W—400W Square Tubular Lamp Design
- Color Temps Available: 3000K—5000K
- CRI > 85—Excellent Color Rendition

Product #	Wattage	Replaces	Lm/W	Lumens	IP Rating	Size	Lens
MHT-TL-100E	100	MH - 200W HPS - 200W	77.5	7,750	65	19"x15"	Glass
MHT-TL-150E	150	MH - 250W HPS - 300W	82.5	12,375	65	22"x15"	Glass
MHT-TL-200E	200	MH - 360W HPS - 400W	82.5	16,500	65	28"x15"	Glass
MHT-TL-250E	250	MH - 400W HPS - 500W	82.5	20,625	65	28"x15"	Glass
MHT-TL-300E	300	MH - 500W HPS - 750W	87.5	26,250	65	28"x15"	Glass
MHT-TL-400E	400	MH - 750W HPS - 750W	87.5	35,000	65	48"x15"	Glass

Available Options:

- Dimmable Ballast



Tunnel Fixtures TL SERIES

Project: _____
 Part Number: _____
 Quantity: _____

ORDERING CODES

MHT-TL - [] E - [] [] - [] - []

Wattage:
100, 150, 200, 250, 300, 400

Color Temp:
3K = 3000K
4K = 4000K
5K = 5000K

Voltage:
U = Universal
3 = 347V

Dimmable Ballast:
DB

Options:
UB = U Bracket
LB = L Bracket

DIMENSIONS

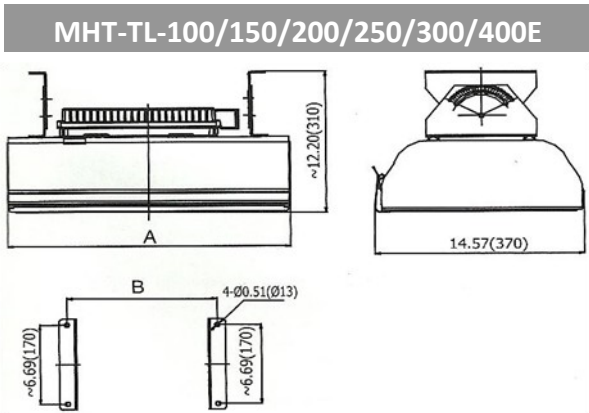

inches (mm)	100E	150E	200E	400E
Length (A)	18.5 (470)	21.7 (550)	35.9 (913)	35.9 (913)
Width	14.6 (370)	14.6 (370)	14.6 (370)	14.6 (370)
B (L Conn)	15.0 (380)	15.8 (400)	19.7 (500)	10.9 (276)
B (U Conn)	12.6 (320)	12.6 (320)	16.5 (420)	27.6 (700)

SAMPLE PHOTOMETRICS

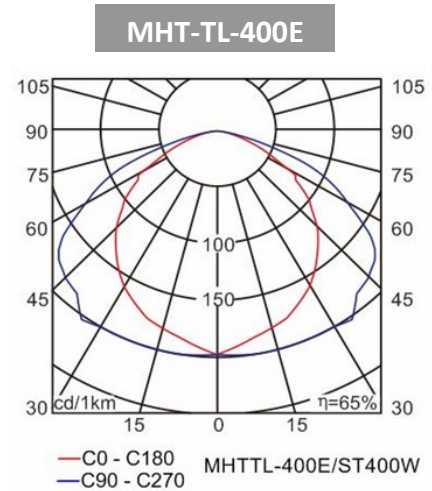
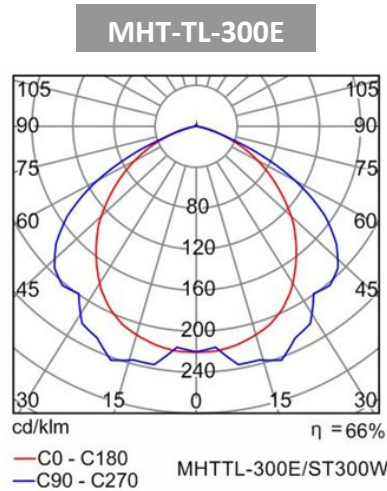
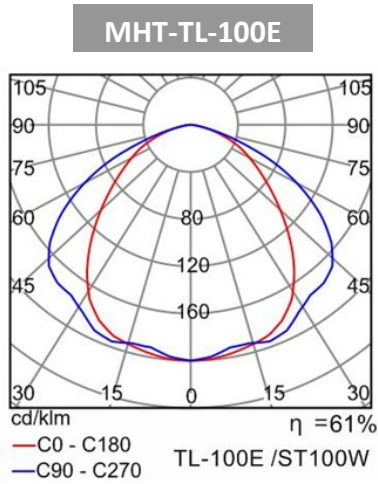

- MHT Products are UL Listed/Labeled and Assembled in ISO9000/1 Certified US Facility
- Every product is quality tested and inspected prior to shipment
- MHT Lighting offers a 10-year, 60,000 hour Warranty (please see Warranty Terms and Conditions)
- Made in the USA of US and Imported Parts, Meets Buy American requirements within the ARRA

MHT Plant Operations
 1961 Richmond Terrace
 Staten Island, NY 10302
 Ph: (718) 524-4370, Fx: (718) 524-4390

West Coast Operations
 2285 Michael Faraday Dr, Ste 15
 San Diego, CA 92154
 Ph: (619) 661-0600, Fx: (619) 661-0607