



Gas Station Fixtures GS SERIES

Project: _____
Part Number: _____
Quantity: _____



APPLICATIONS

- Gas Stations
- Canopies

** Standard Color is WHITE for Gas Station Canopies

FEATURES

- 100,000 Hour Lifespan (IESNA)
- 10 Year or 60,000 Hour Warranty
- High Pressure Die-casted, Powder Coated Aluminum Housing
- Clear Tempered Glass or UV Stabilized Polycarbonate Lens
- Surface Mounting
- Custom Colors Available
- Ambient Temp Range: -30 to 130 deg F



LAMP/GENERATOR

- 120-277V Universal Electronic Ballast
- Available 0-10V Dimmability, 2-way Communication
- Power Factor > 0.95, Operation Frequency 50-60Hz
- Instant-On, Flicker Free, Minimum Light Loss
- 40W—150W Square Tubular Lamp Design
- Color Temps Available: 3000K—5000K
- CRI > 85—Excellent Color Rendition

Product #	Wattage	Replaces	Lm/W	Lumens	IP Rating	Size	Lens
MHT-GS-40E	40	MH - 120W	72.5	5,075	65	19.7"x13.8"	Glass,
MHT-GS-70E	70	MH - 120W	72.5	5,075	65	19.7"x13.8"	Glass,
MHT-GS-100E	100	MH - 200W	77.5	7,750	65	19.7"x13.8"	Glass,
MHT-GS-150E	150	MH - 250W	82.5	12,375	65	19.7"x13.8"	Glass,

* other wattages available upon request

Available Options:

- Dimmable Ballast
- Custom Colors Available



Gas Station Fixtures GS SERIES

Project: _____
 Part Number: _____
 Quantity: _____

ORDERING CODES

MHT-GS - E - - - -

Wattage: 40, 70, 100, 150	Color Temp: 3K = 3000K 4K = 4000K 5K = 5000K	Voltage: U = Universal 3 = 347V	Dimmable Ballast: DB	Options: GL = Glass Lens PC = Drop PC Lens CC = Custom Color (Specify)
--	--	--	------------------------------------	--

DIMENSIONS

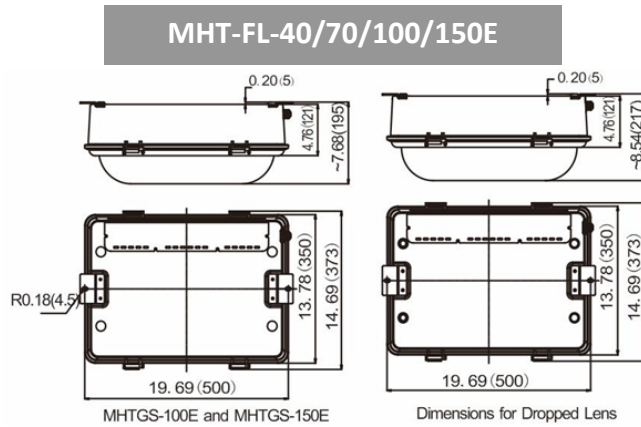

SAMPLE PHOTOMETRICS

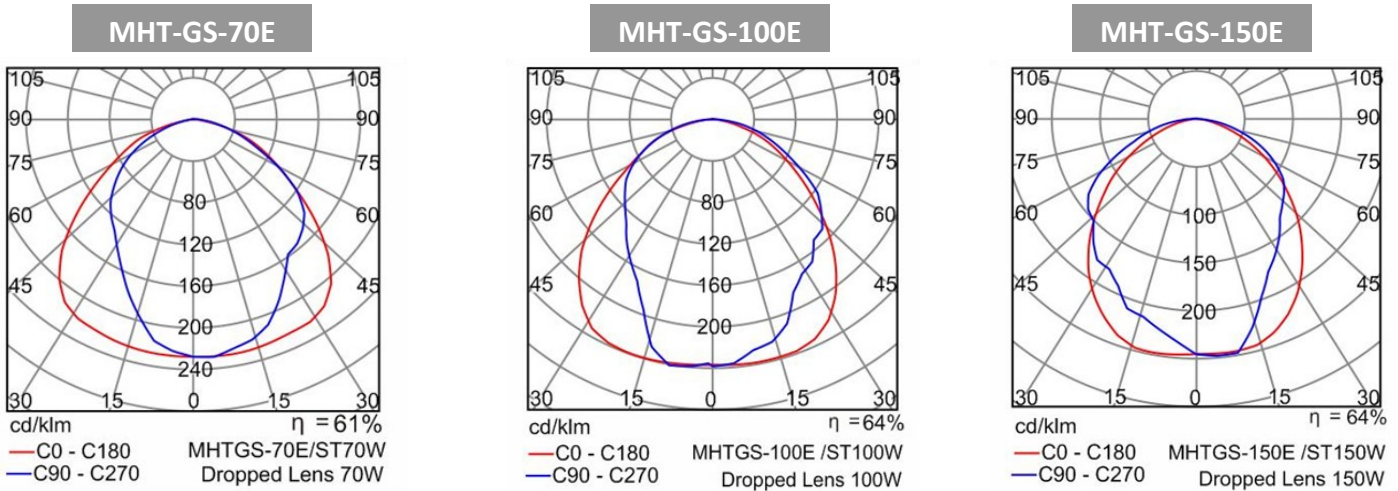

- MHT Products are UL Listed/Labeled and Assembled in ISO9000/1 Certified US Facility
- Every product is quality tested and inspected prior to shipment
- MHT Lighting offers a 10-year, 60,000 hour Warranty (please see Warranty Terms and Conditions)
- Made in the USA of US and Imported Parts, Meets Buy American requirements within the ARRA

MHT Plant Operations
 1961 Richmond Terrace
 Staten Island, NY 10302
 Ph: (718) 524-4370, Fx: (718) 524-4390

West Coast Operations
 2285 Michael Faraday Dr, Ste 15
 San Diego, CA 92154
 Ph: (619) 661-0600, Fx: (619) 661-0607