



# Freezer Light Fixtures FL SERIES

Project: \_\_\_\_\_  
Part Number: \_\_\_\_\_  
Quantity: \_\_\_\_\_



## APPLICATIONS

- Freezers
- Cold Storage
- Food, Agriculture
- SAVE ENERGY with INSTANT ON OCC SENSORS

## FEATURES

- 100,000 Hour Lifespan (IESNA)
- 10 Year or 60,000 Hour Warranty
- High Pressure Die-casted, Powder Coated Aluminum Housing
- Clear Tempered Glass or UV Stabilized Polycarbonate Lens
- Surface Mounting
- Custom Colors Available
- Ambient Temp Range: -40 to 120 deg F



## LAMP/GENERATOR

- 120-277V Universal Electronic Ballast
- Available 0-10V Dimmability, 2-way Communication
- Power Factor > 0.95, Operation Frequency 50-60Hz
- Instant-On, Flicker Free, Minimum Light Loss
- 40W—150W Square Tubular Lamp Design
- Color Temps Available: 3000K—5000K
- CRI > 85—Excellent Color Rendition

Product #	Wattage	Replaces	Lm/W	Lumens	IP Rating	Size	Lens
MHT-FL-40E	40	MH - 120W HPS - 150W	72.5	5,075	65	19.7"x13.8"	Glass, Polycarbonate
MHT-GS-70E	70	MH - 120W HPS - 150W	72.5	5,075	65	19.7"x13.8"	Glass, Polycarbonate
MHT-GS-100E	100	MH - 200W HPS - 200W	77.5	7,750	65	19.7"x13.8"	Glass, Polycarbonate
MHT-GS-150E	150	MH - 250W HPS - 300W	82.5	12,375	65	19.7"x13.8"	Glass, Polycarbonate

\* other wattages available upon request

### Available Options:

- Dimmable Ballast
- Custom Colors Available



# Freezer Light Fixtures FL SERIES

Project: \_\_\_\_\_  
 Part Number: \_\_\_\_\_  
 Quantity: \_\_\_\_\_

## ORDERING CODES

**MHT-FL** -  **E** -   -  -  -

**Wattage:** 40, 70, 100, 150  
**Color Temp:** 3K = 3000K, 4K = 4000K, 5K = 5000K  
**Voltage:** U = Universal  
**Dimmable Ballast:** DB  
**Options:** GL = Glass Lens, PC = Drop PC Lens, CC = Custom Color (Specify)

## DIMENSIONS

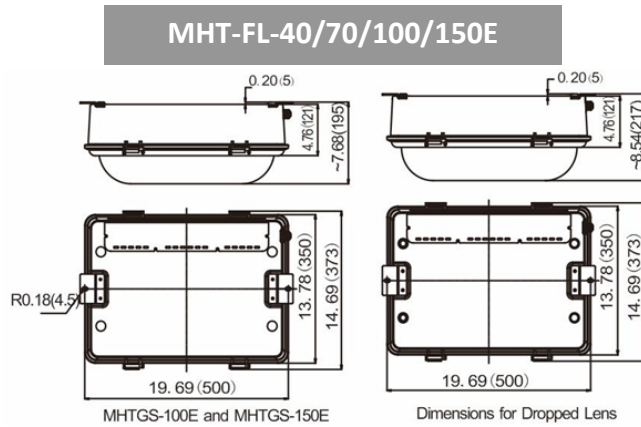

## SAMPLE PHOTOMETRICS

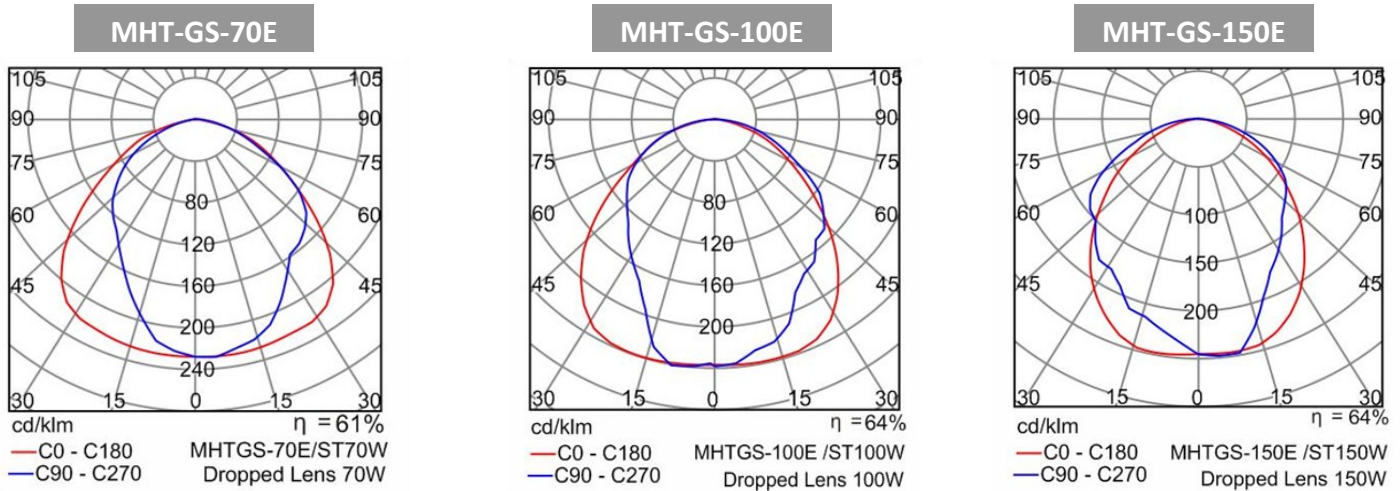

- MHT Products are UL Listed/Labeled and Assembled in ISO9000/1 Certified US Facility
- Every product is quality tested and inspected prior to shipment
- MHT Lighting offers a 10-year, 60,000 hour Warranty (please see Warranty Terms and Conditions)
- Made in the USA of US and Imported Parts, Meets Buy American requirements within the ARRA

MHT Plant Operations  
 1961 Richmond Terrace  
 Staten Island, NY 10302  
 Ph: (718) 524-4370, Fx: (718) 524-4390

West Coast Operations  
 2285 Michael Faraday Dr, Ste 15  
 San Diego, CA 92154  
 Ph: (619) 661-0600, Fx: (619) 661-0607